

BridgeClip®

Secures Channel to Stud

Material Composition

BridgeClip: ASTM A1003/A1003M Structural Grade 50 (340) Type H, ST50H (ST340H): 50ksi (340MPa) minimum yield strength, 65ksi (450MPa) minimum tensile strength, 33mil minimum thickness (20 gauge, 0.0346" design thickness) with ASTM A653/A653M G90 (Z275) hot dipped galvanized coating.

BC600 & BC800: ASTM A1003/A1003M Structural Grade 50 (340) Type H, ST50H (ST340H): 50ksi (340MPa) minimum yield strength, 65ksi (450MPa) minimum tensile strength, 43mil minimum thickness (18 gauge, 0.0451" design thickness) with ASTM A653/A653M G90 (Z275) hot dipped galvanized coating.

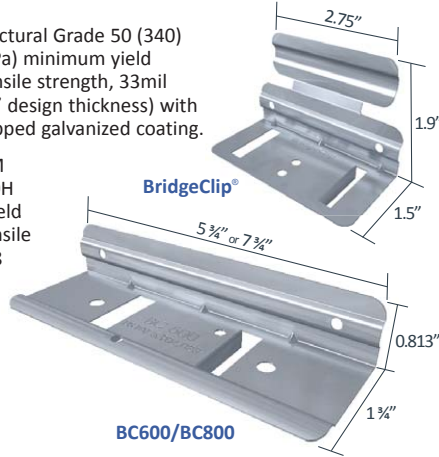

US Patent #5,904,023

BridgeClip Allowable Loads

Designation	F1 (lbs)	M1 (in-lbs)
BridgeClip (1) Screw	75	180
BridgeClip (3) Screws	360	340
BC600	360	720
BC800	360	720

Notes:

- Design loads based on clip capacity only (verify screw shear and pullout at stud web).
- Allowable loads have not been increased for wind, seismic, or other factors.
- Resists both lateral and twisting loads.

Nomenclature

BridgeClip is available in 3-5/8", 6" and 8". Designations are BridgeClip®, BC600 & BC800.

Example: 6" Stud
Designate: BC600

Load Direction

