

Drywall Accessories

Corner Bead

Product #	Dimensions/Descriptions	Pieces/Box
209	Drywall corner bead, 1-1/4" x 1-1/4" flange.	100
8' & 10' Lengths		

Note: Stritations on exposed flanges

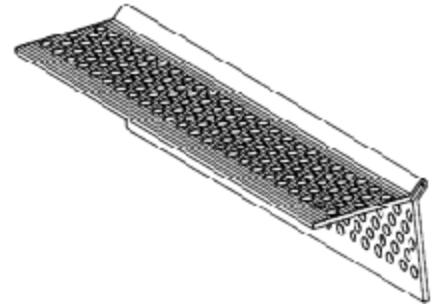

● Application: 209

To be used on all outside corners. Rust and impact resistant. Tapered legs are perforated and striated for better adhesion; eliminates the need to tape the flange. Prevents electrolysis. 8' & 10' lengths

● Specification:

Corner Bead shall be Plastic Components, Inc. # 209. All drywall accessories shall conform to ASTM standards D3678-92 and C1047-94. Finish compatible with drywall mud and all paint finishes. They shall be used where specified by the architect and installed per industry standards and manufacturer's instructions.

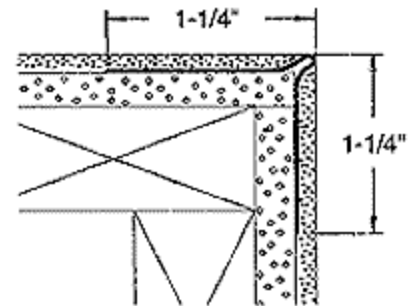

Drywall Accessories

Arch Corner Bead

Product #	Dimensions/Descriptions	Pieces/Box
209A	Drywall corner bead, 1-1/4" x 1-1/4" flange- one leg slotted.	100
8' & 10' Lengths		

Note: Stritations on exposed flanges.

● Application: 209A

To be used where a curve or arch is formed. Pre-slotted flange allows for perfect arches. Tapered flanges are perforated and striated for better adhesion; eliminates the need to tape the flange. 8' & 10' lengths

● Specification

Arch Bead shall be Plastic Components, Inc. # 209A. All drywall accessories shall conform to ASTM standards D3678-92 and C1047-94. Finish compatible with drywall mud and all paint finishes. They shall be used where specified by the architect and installed per industry standards and manufacturer's instructions

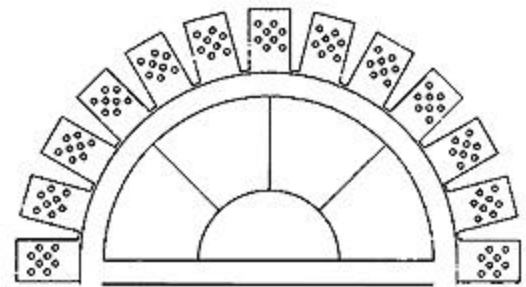
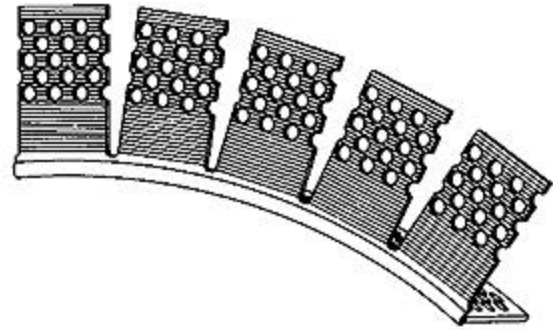

flanges.

It is recommended that PVC products be used for all interior applications.

