

Stucco and Plaster

Drip Screed

Product #	Ground	Dimensions/Descriptions	Pieces/Box
540-38	3/8"	Soffit drip screed with 2" x 2" perforated flange.	15
540-50	1/2"		15
540-58	5/8"		15
540-75	3/4"		15
540-78	7/8"		15
10' Lengths			

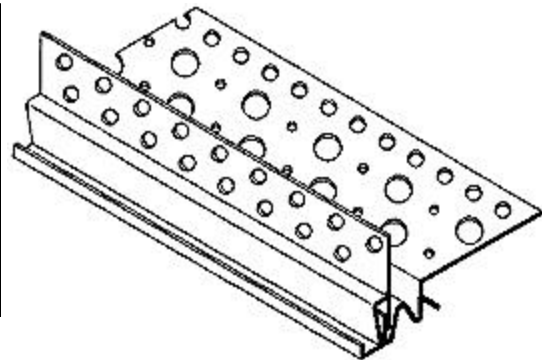

Application:

Prevents water from turning under and back into the soffit. Also serves as an expansion joint.

Specification:

Drip Screed shall be Plastic Components, Inc. # _____. All exterior accessories shall be of PVC material conforming to ASTM standards D1784-92 and C1063-94. They shall be used where specified by the architect and installed per industry standards and manufacturer's instructions.

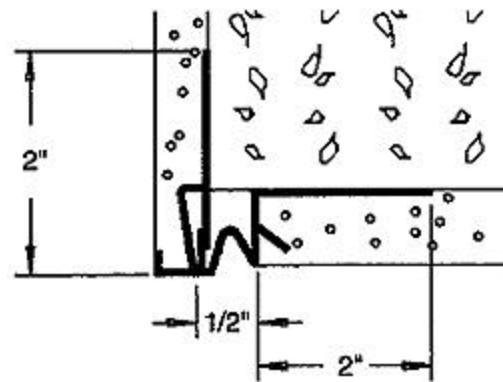

Caulk all butt joints, intersections and ends.

It is recommended that PVC products be used for all exterior exposures.

