

Stucco and Plaster

"F" Plaster Reveal

Product#	Dimension A	Dimension B	Pieces/Box
F707-50	1/2"	1/2"	35
F708-25	3/4"	1/4"	50
F708-38	3/4"	3/8"	35
F708-50	3/4"	1/2"	35
F708-58	3/4"	5/8"	30
F708-75	3/4"	3/4"	30
F709-25	1"	1/4"	50
F709-38	1"	3/8"	35
F709-50	1"	1/2"	20
F709-58	1"	5/8"	20
F709-75	1"	3/4"	20
F710-25	1-1/2"	1/4"	50
F710-38	1-1/2"	3/8"	35
F710-50	1-1/2"	1/2"	20
F710-58	1-1/2"	5/8"	20
F710-58	1-1/2"	5/8"	20
F710-58	1-1/2"	5/8"	20

Removable caps on all except 1/4" ground. 10' Lengths

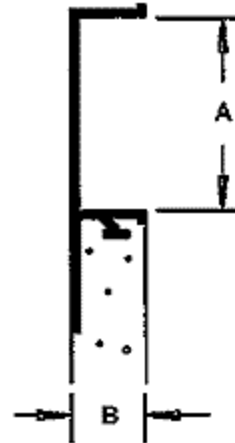
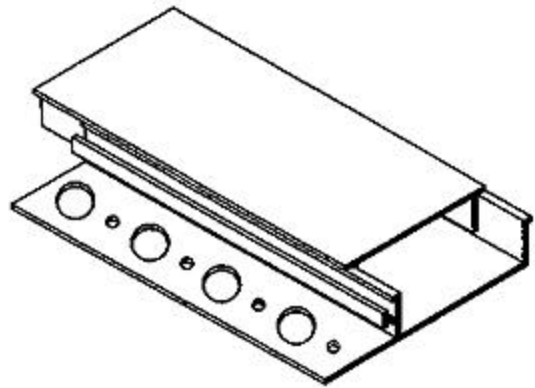

Application:

Serves same aesthetic value as ULTRA-TRAC reveal. Provides termination reveal molding at windows, door jambs, soffit or at any other dissimilar materials.

Specification:

"F" Plaster Reveals shall be Plastic Components, Inc. #_____. All exterior accessories shall be of PVC material conforming to ASTM standards D1784-92 and C1063-94. They shall be used where specified by the architect and installed per industry standards and manufacturer's instructions.

Product#	Dimension A	Dimension B	Pieces/Box
F711-25	2"	1/4"	40

F711-38	2"	3/8"	35
F711-50	2"	1/2"	20
F711-58	2"	5/8"	20
F711-75	2"	3/4"	20
F712-50	2-1/2"	1/2"	13
F712-58	2-1/2"	5/8"	13
F712-75	2-1/2"	3/4"	13
F713-50	3"	1/2"	13
F713-58	3"	5/8"	13
F713-75	3"	3/4"	13
F714-50	4"	1/2"	13
F714-75	4"	3/4"	13
Removable caps on all except 1/4" ground. 10' Lengths			

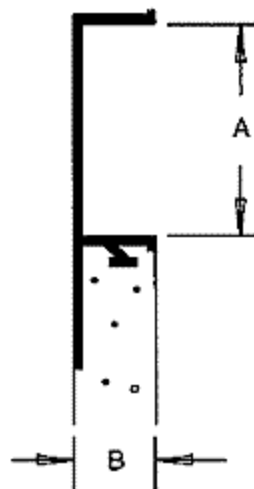
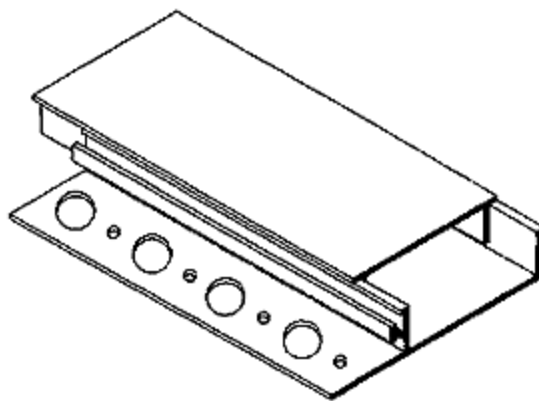

● Application:

Serves same aesthetic value as ULTRA-TRAC reveal. Provides termination reveal molding at windows, door jambs, soffit or at any other dissimilar materials.

● Specification:

"F" Plaster Reveals shall be Plastic Components, Inc. #_____. All exterior accessories shall be of PVC material conforming to ASTM standards D1784-92 and C1063-94. They shall be used where specified by the architect and installed per industry standards and manufacturer's instructions.

Caulk all butt joints, intersections and ends.
It is recommended that PVC products be used for all exterior exposures.

