

Stucco and Plaster

Slip Joint

Product #	Ground	Dimensions/Descriptions	Pieces/Box
2079	3/8"	Slip joint- wide perforated flanges adjust from 0" to 5/8".	25
2080	1/2"		25
2081	3/4"		25
2082	7/8"		20
10' Lengths			

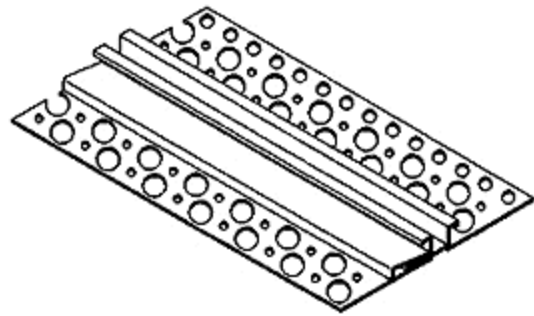

Application:

Used as an expansion joint while providing a reveal. Designed to expand and contract where severe movement is anticipated. When used in vertical application, the lath should be split before installing the slip joint. When used in a horizontal plane, the same procedure should be used before placing the female side to top.

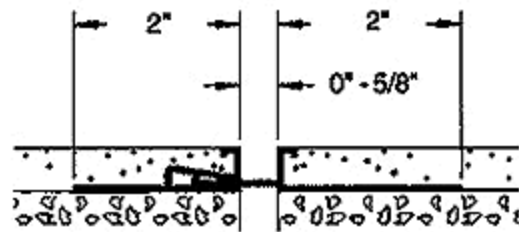

Specification:

Slip Joint shall be Plastic Components, Inc. # _____. All exterior accessories shall be of PVC material conforming to ASTM standards D1784-92 and C1063-94. They shall be used where specified by the architect and installed per industry standards and manufacturer's instructions.

Caulk all butt joints, intersections and ends.

It is recommended that PVC products be used for all exterior exposures.

